

CHYI MEANG MACHINERY CO., LTD.

HIGH PRESSURE GRINDING ROLLS

MG900

MG700

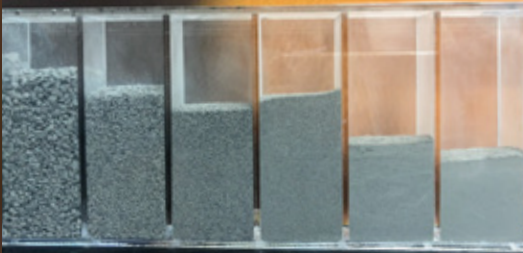

Cubic Product Shape Low Consumable Cost Less Noise
High Capacity High Efficiency



Specification

Equipment	HIGH PRESSURE GRINDING ROLLS	
Model Name	MG900	MG700
PERFORMANCE		
Capacity	120 ~ 150 TPH	85 ~ 110 TPH
Speed (Rpm)	27 ~ 36 RPM	29 ~ 38 RPM
Feed Opening	530 * 580 mm	400 * 420 mm
Discharge Opening	MAX 27 mm	MAX 20 mm
Motor	2 PCS	2 PCS
Power (Hp)	175 HP	100 HP
Rolls	2 PCS	2 PCS
Rolls (Diameter X Width)	880 * 580 mm	680 * 420 mm
Tungsten Carbide	1700 PCS	1064 PCS
OUTER DIMENSION		
Length*Width*Height	4541 * 3613 * 3065 mm	3720 * 2820 * 2715 mm
Weight	36000 KG	26000 KG

- The Capacity And The Rolls Wear Will Have $\pm 8\%$ Difference Based On Types And Hardness Of Stone And Material Moisture Content
- All Pictures Shown Are For Illustration Purpose Only. Actual Product May Vary Based On Quotation And Contract.

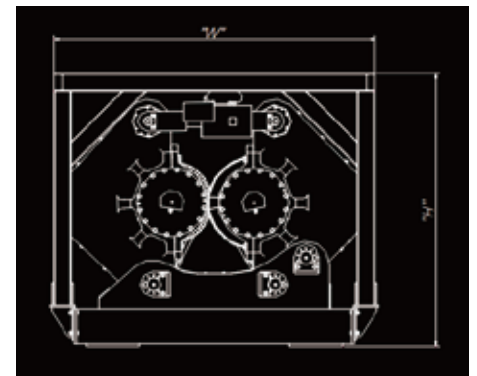
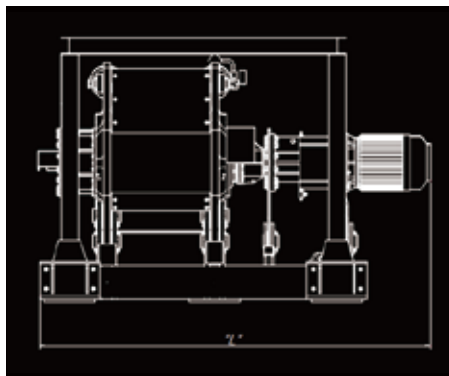
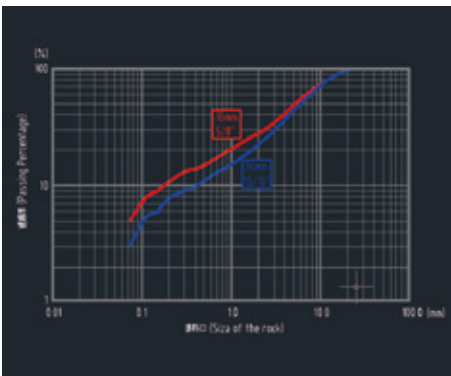

桃園廠 Main Office & Factory (Taoyuan) 334029 桃園市八德區介壽路二段535號
No. 535, Sec. 2, Jieshou Rd., Bade Dist., Taoyuan City 334029, Taiwan (R.O.C.) Tel:886-3-3666168 Fax:886-3-3668366

雲林廠 Office & Factory (Yunlin) 643004 雲林縣林內鄉重興村68之50號
No. 68-50, Chongxing Village, Linnei Township, Yunlin County 643004, Taiwan (R.O.C.) Tel:886-5-5890168 Fax:886-5-5890169

屏東廠 Office & Factory (Pingtung) 905004 屏東縣里港鄉三和路119之66號
No. 119-66, Sanhe Rd., Ligang Township, Pingtung County 905004, Taiwan (R.O.C.) Tel:886-8-7733735 Fax:886-8-7733732

